

**N2KMeter®
NMEA 2000® Diagnostic Tool**

User's Manual

Revision 1.3

Copyright © 2017 Maretron, LLP All Rights Reserved

Maretron, LLP
9014 N. 23rd Ave #10
Phoenix, AZ 85021-7850
<http://www.maretron.com>

Maretron Manual Part #: M000701

Table of Contents

1	General	2
	1.1 Introduction	2
	1.2 Features.....	2
2	Installation	2
	2.1 Unpacking the Box.....	2
3	Essentials.....	3
	3.1 Batteries.....	3
	3.2 AutoSearch Mode	3
	3.3 NMEA 2000® Cable	3
4	How to use this manual	4
5	Using the N2KMeter	5
	5.1 Viewing Measurements.....	5
	5.2 Display Lock	5
	5.3 Resetting Min/Max Measurements.....	5
6	Display	6
7	Bus Errors (Switch Position 2).....	7
8	Bus Traffic (Switch Position 3)	9
9	Bus Power (Switch Position 4)	11
	9.1 What's a Transient?	11
10	Shield Voltage (Switch Position 5)	13
	10.1 About NMEA 2000® Shield Voltage	13
11	CAN Primer	15
12	Common Mode Voltage (Switch Position 6)	17
	12.1 What is Common Mode Voltage?	17
13	NET-H/L Differential V Recessive (Switch Position 7).....	19
	13.1 Importance of NET-H/L Differential V Recessive Measurement	19
	13.2 What is "recessive?"	20
14	NET-H/L Differential V Dominant (Switch Position 8).....	21
	14.1 What is "Dominant"?	21
15	CAN Signal Thresholds (Switch Positions 9-12)	23
16	NMEA 2000® Glossary	24
17	Switch Settings.....	25
18	Certifications	25
19	Cables.....	26
20	Hexadecimal to Decimal Conversion Table.....	27
21	Specifications	28
22	Technical Support	28
23	Maretron (90-Day) Limited Warranty	29

Revision History

Rev.	Description
1.2	Updated Company Address
1.3	Changed cable part number

1 General

1.1 Introduction

Congratulations on your purchase of the Maretron N2KMeter. The N2KMeter is a diagnostic tool for NMEA 2000® networks that allows users to validate NMEA 2000® network compatibility and operations during installation of a device or complete system, and diagnose possible network flaws or failures that occur on an operational network.

Please read carefully and follow these instructions for usage of the Maretron N2KMeter in order to ensure optimal performance and accurate measurements.

1.2 Features

The N2KMeter uses a patented integrated intelligence technique to summarize multiple NMEA 2000® network operational variables into a single health index. To a service technician, it's a "guru-in-a-box", providing a detailed reading of network performance. It summarizes NMEA 2000® network health by displaying a happy face icon (☺), indicating a healthy network; a sad face (☹), indicating a serious problem; or a neutral face (☺), indicating nominal performance (a good indication to repair things before they actually fail). The N2KMeter then walks the user through each fault condition and its source, or it can record key operating parameters for offline review.

Faults that can be detected by the N2KMeter include

- Opens and Shorts
- Incorrect Topology
- Bad Nodes
- Bad Termination
- Improper Shield Connection
- Intermittent Problems
- Excessive Scan Rate
- Common Mode Voltage

2 Installation

2.1 Unpacking the Box

When unpacking the box containing the Maretron N2KMeter, you should find the following items.

- 1 – N2KMeter Diagnostic Tool
- 1 – NMEA 2000® Adapter Cable
- 1 – N2KMeter User's Manual (Includes Warranty Statement and Registration)
- 2 – "AA" Alkaline Batteries

If any of these items are missing or damaged, please contact Maretron.

3 Essentials

3.1 Batteries

The N2KMeter requires 2 “AA” alkaline batteries for viewing measurements offline. The N2KMeter must be plugged into a powered network to get most measurements. The N2KMeter will run off NMEA 2000® network power, even without batteries installed. Remember to install batteries if you plan to use the Lock and offline viewing features.

3.2 AutoSearch Mode

AutoSearch mode saves you time by finding the network measurements that exceed acceptable limits. It works by examining all measurements and then pinpointing any that exceed or are close to specified limits. For each problem measurement, the N2KMeter indicates the measurement’s switch position number in the upper left corner of the display. Rotate the selector switch to the indicated setting to view related measurements. To use AutoSearch, follow these simple instructions:

1. Make sure the Lock switch is in the “Run” position and turn the selector switch to AutoSearch
2. If you see ☺, all measurements are within limits.
3. If you see ☹ or ☹, then read the display like this ...
“Switch setting <Setting #>, <MIN> or <MAX> and/or <P-P> is close to ☹ or Exceeds ☹ the spec limits.”

Then press ▶ and repeat the process for the next bad/marginal value. To get more detail, turn the selector switch to the indicated position and use the buttons ▶, ⊕, and ⊖ to access related measurements.

3.3 NMEA 2000® Cable

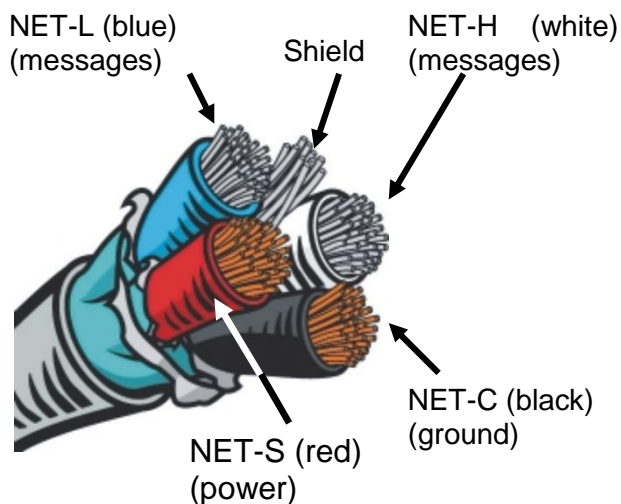

NMEA 2000® cable has five wires inside. Each has a specific purpose that is referenced in this manual.



4 How to use this manual

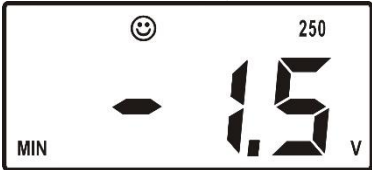

The N2KMeter has a large selector switch with 12 different positions. For each switch position, you will find a section in this reference manual explaining the measurements available and suggested actions and/or remedies if your network is not healthy. In each section, you'll find a diagram showing the display, button push and display reading description as shown below.

LCD Display *Push the Advance button* *Description*

The minimum shield voltage recorded since the N2KMeter was plugged in or reset is -1.5V.

of times to push the advance button after moving the selector switch to display this measurement.

Displays the maximum frame rate per second on the network since the N2KMeter was plugged in or reset.

Viewing measurement for this device (Node Address).

You can view this measurement for each active device by pressing the **+** or **-** buttons. Pressing **+** and **-** at the same time displays the overall network measurement again.

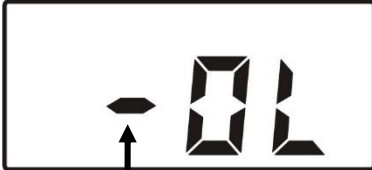

The measured value exceeds the positive or negative input range.

Sign indicates negative over-range



No measurement taken (see additional details for specific measurements).

NOTE: Node Addresses are displayed by the N2KMeter in hexadecimal notation. Some network design specifications may refer to node addresses with decimal notation. Please refer to the conversion table in Section 20 on page 27 to convert between the two notations.



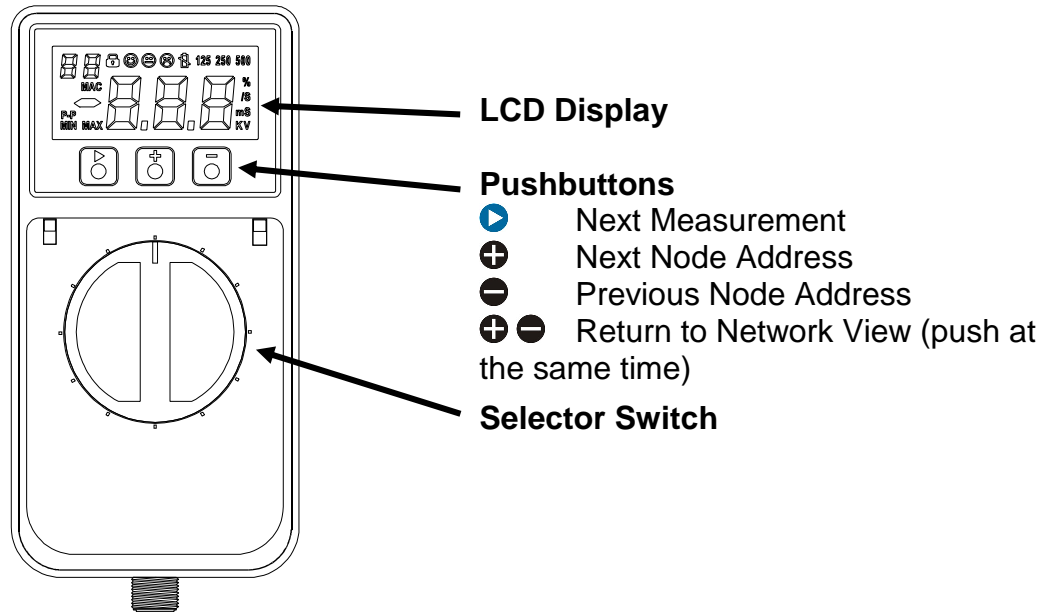

5 Using the N2KMeter



5.1 Viewing Measurements

Each selector switch position accesses a different bus measurement, and each supports several different measurement types.

Pressing  cycles the display through the different measurements available at each switch position.

Some measurements allow a detailed view for each Node Address. Press  OR  to cycle through the active Node Addresses. Press  AND  together to return to the overall network view.

5.2 Display Lock

To lock measurements for offline viewing, move the lock switch to the  position. To erase stored values and restart bus analysis move the lock switch to "Run".

Stored values are retained indefinitely, providing the lock switch is left in the  position, and the batteries are good - even if the meter is turned off.

5.3 Resetting Min/Max Measurements

The N2KMeter is reset (Min/Max and other stored measurements cleared) when the Lock switch is moved to the "Run" position, and when the power switch is turned On while the Lock switch is in the "Run" position.

You may reset stored measurements by either turning the meter off and on again, or by moving the Lock switch to  and back to "Run".

6 Display

The N2KMeter LCD display includes a large 3-digit display as well as 17 other indicators that are shown in the following diagram.

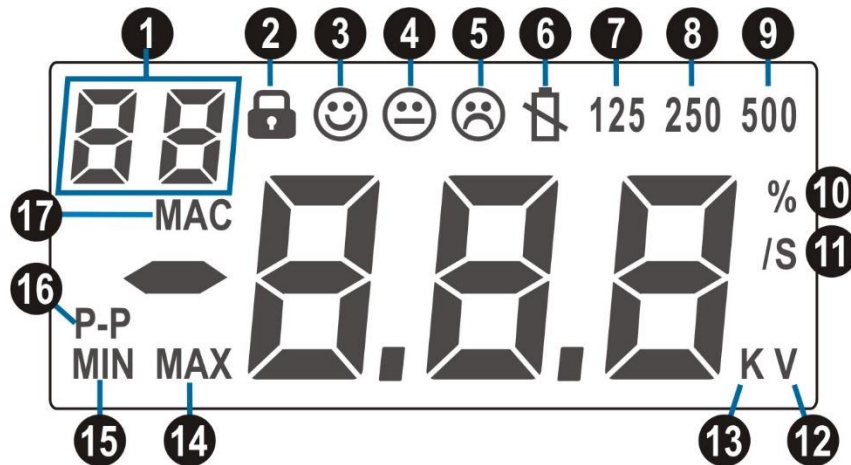

- 1 Network Node Address (node #) or N2KMeter switch setting number (AutoSearch)
- 2 Display Locked indicator (“lock” switch is on)
- 3 Measurement displayed is acceptable
- 4 Measurement displayed is marginal
- 5 Measurement displayed is unacceptable
- 6 Battery low – stored measurements may be lost
- 7 125 Kbaud network activity detected
- 8 250 Kbaud network activity detected
- 9 500 Kbaud network activity detected
- 10 Measurement unit is % bandwidth
- 11 Measurement unit is errors / messages per second
- 12 Measurement unit is volts
- 13 Measurement displayed is in thousands (kilo)
- 14 Measurement displayed is a maximum value
- 15 Measurement displayed is a minimum value
- 16 Measurement displayed is a peak-to-peak value
- 17 Displayed when viewing measurements for a particular Node Address. Not displayed in AutoSearch mode when the value shown in the top left corner is a switch position.

NOTE: If none of MIN, MAX or P-P is shown then the value displayed is a “live” measurement or the most recent “Live” measurement if the “lock” switch is on.

7 Bus Errors (Switch Position 2)

The N2KMeter tracks network data transmission errors in real-time, and lets you know if the error rate is acceptable 😊, marginal 😐, or unacceptable 😞. Any error rate greater than zero is undesirable (although your network may still function since CAN automatically retransmits after errors). An error rate greater than 10/s indicates a problem that should be investigated.

The N2KMeter uses unique technology to accurately determine which node was attempting to transmit when a bus error occurs.

Display

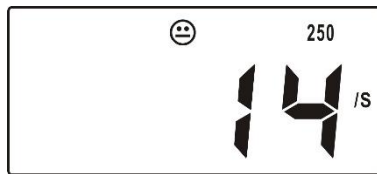

What it means

Real-time error rate of 14 errors/second



Minimum bus error rate on whole network since N2KMeter was connected to the network or reset.

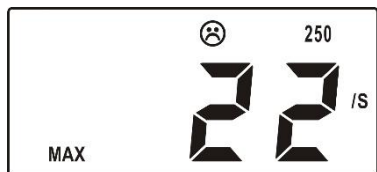

Maximum bus error rate on the whole network since N2KMeter was connected or reset.



Incremental error count on the entire network since the N2KMeter was connected or reset.

NOTE: Node error measurements only include errors known to have occurred when the node is transmitting. Frames with corrupt ID fields, and frames that cannot be attributed to specific nodes are not included in node measurements. It is common for the sum of per-node results to be less than the overall network values.

Thresholds

Error Rate High Fault	😞	15 /s
Error Rate High Warn	😐	1 /s

What to do when you see ☺ or ☹:

- Press ⊕ or ⊖ to identify the device(s) with higher error rates than other nodes. calculate the ratio of error rate to frame rate of suspect nodes and check for above average ratios. Devices with above average error ratios should be investigated further.
- Check the other measurements and investigate the suspect device(s) for faults consistent with the observed symptoms.
Some techniques you can use are:
 - Replace the device and/or cabling.
 - Temporarily remove the device from the network to see if the errors cease.
- If you suspect an intermittent cable or connector, shake, bend or twist the suspected cable and/or connector while watching the error rate for changes (up or down).

Excessive cable lengths and faulty nodes can cause errors in the transmissions of some/all other nodes. Do not assume that the node(s) with the highest error rate is faulty.

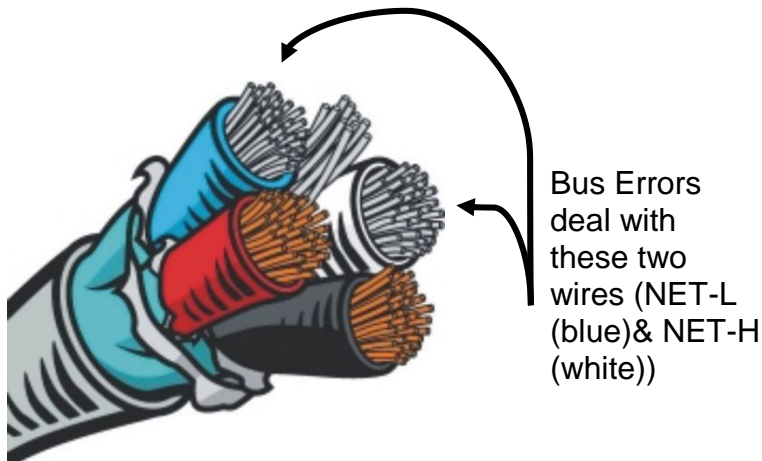

8 Bus Traffic (Switch Position 3)

The N2KMeter continuously monitors the CAN bit-stream for message traffic. The N2KMeter reports Bus Traffic as either network bandwidth consumed (including bandwidth consumed by errors/retries) or bus frames per second.

Display



What it means

Current network or node bandwidth utilization.



Minimum network or node bandwidth recorded since the N2KMeter was plugged into the network or reset.



Maximum network or node bandwidth recorded since N2KMeter was connected or reset.



Number of message frames per second on the network or node.



Minimum frame rate (/S) on the network or node since the N2KMeter was plugged in or reset.



Maximum frame rate (/S) on the network or node since the N2KMeter was plugged in or reset.









Thresholds

Bus Traffic High Warn ☹️ 90.0%

NOTE: NMEA 2000® networks tend to produce more messages for a short time after power up because of proprietary configuration messaging. With the N2KMeter, you can capture this higher bandwidth usage during startup by observing the maximum reading. You can also get a more realistic measurement of the actual network bandwidth (without initialization messaging) by resetting the maximum value (switch the N2KMeter off and then back on).

9 Bus Power (Switch Position 4)

The N2KMeter continuously monitors the NMEA 2000® bus power quality.

Display	What it means
	Current network bus voltage is 12.2V.
	 Minimum bus voltage recorded since N2KMeter was plugged in or reset is 12.1V.
	 Maximum bus voltage recorded since N2KMeter was plugged in or reset is 12.4V.
	 Current peak-to-peak (P-P) voltage (transient or ripple) is 0.1Vp-p.
	 <ul style="list-style-type: none">Maximum peak-to-peak (P-P) voltage recorded since N2KMeter was plugged in or reset is 0.2V.

9.1 What's a Transient?

A transient is a short, temporary deviation of the bus voltage level.

Every NMEA 2000® network has some level of bus power transients, which is perfectly acceptable. Transients in excess of 2V P-P can contribute to node failures and communication errors in some cases and should be investigated. Transients in excess of 10V P-P are an indication of serious network problems.

Examples of Transients

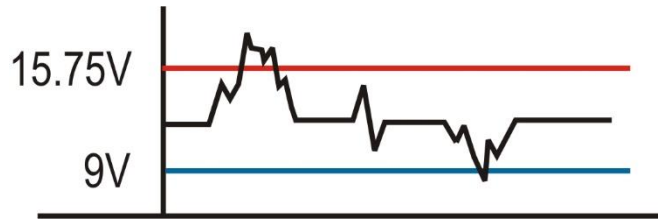

Thresholds

High Voltage Fault	☹	15.75V
Low Voltage Warning	☺	10.0V
Low Voltage Fault	☹	9.0V
High P-P Voltage Fault	☹	5.0V
High P-P Voltage Warning	☺	2.0V

For ☹ Bus Power Voltage Levels We Suggest:

- Check your power supply for proper installation and correct output voltage under load.
- Are your trunk/drop cables too long?
- Is one or more of your devices drawing too much current?

For ☹ P-P (noise) Levels We Suggest:

- Check for output devices (containing relays or power electronics) powered from the network (they shouldn't be).
- Check for network cables routed too close to strong sources of interference.
- Check for aging network power supply with output ripple increasing over time.
- If you suspect an intermittent cable or connector, shake, bend, or twist the suspected cable and/or connector while watching the P-P measurement for changes (up or down).

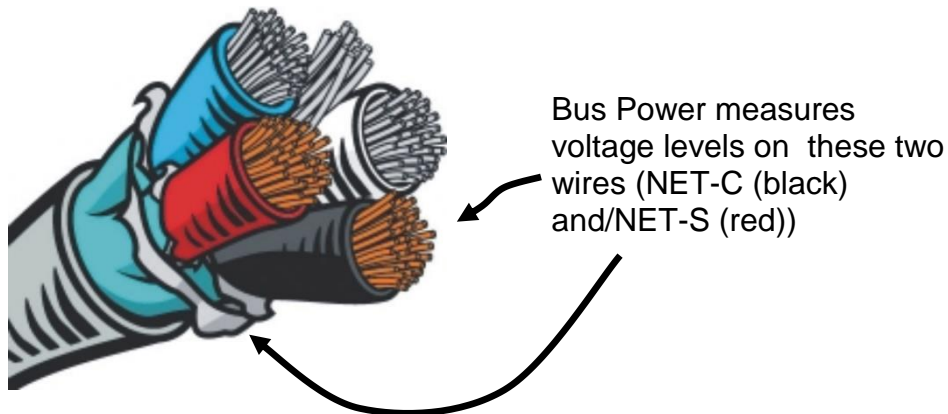

10 Shield Voltage (Switch Position 5)

The N2KMeter measures live, minimum, and maximum DC shield voltage (between shield and NET-C).

Display



What it means

Current shield voltage is -1.4V.

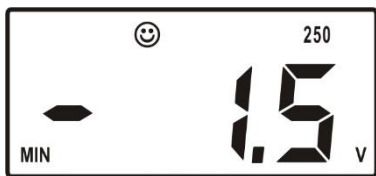

The minimum shield voltage recorded since the N2KMeter was plugged in or reset is -1.5V.

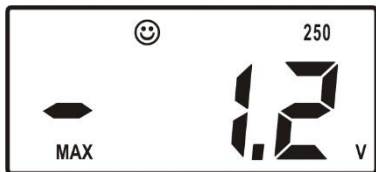

The maximum shield voltage recorded since the N2KMeter was plugged in or reset is -1.2V.

Thresholds

High Voltage Fault	☹	1.0V
High Voltage Warning	☺	0.3V
Low Voltage Warning	☺	-2.0V
Low Voltage Fault	☹	-2.5V

10.1 About NMEA 2000® Shield Voltage

The NMEA 2000® specification requires that the shield and NET-C be connected together at the power supply. This has the following effects:

- A correctly connected shield has no current flow in it and is at the same voltage (grounded power supply NET-C) throughout the system.
- Current flow in NET-C causes a voltage rise in NET-C
- Rising NET-C voltage causes an apparent negative shift in the shield voltage when measured relative to NET-C
- Since the maximum allowable voltage drop in NET-C is 2.5V, the negative shift in shield voltage is between -2.5V and 0V

Systems connected in accordance with the NMEA 2000® installation guidelines have a "normal" shield voltage between -2.5V and 0V.

For ☹ shield voltage levels we suggest:

- Make sure the shield and NET-C are connected to each other and to earth ground at the power supply (very important)
- Check for shorted or open shield wiring
- Check that your shield wire is actually grounded correctly (it's so important you check it twice!)
- The N2KMeter displays "OL" if the shield is not connected (or if the voltage is high).

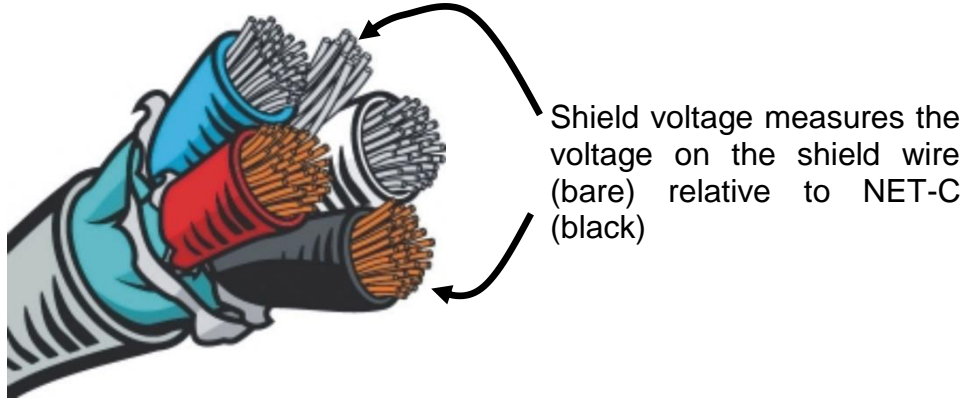

11 CAN Primer

NMEA 2000[®] is based on the CAN protocol. A fundamental understanding of CAN will help you take full advantage of the N2KMeter's features and significantly improve your ability to diagnose network problems quickly.

CAN messages are transmitted as a difference in voltage between two separate wires, NET-H (white) and NET-L (blue). Differential transmission helps CAN and NMEA 2000[®] to operate well even with high levels of external interference (i.e., from sources like winch motors, radars, etc.) Here's what you might see if you captured CAN signals on an oscilloscope:

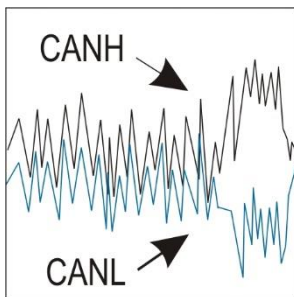

Individual wires include data + noise

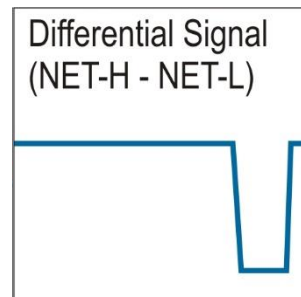

Differential receiver cancels noise and extracts data signal

CAN signals have two states, dominant (0) and recessive (1). The transceiver in each NMEA 2000[®] node determines whether a signal is a 1 or a 0 based on the differential voltage between NET-H and NET-L.

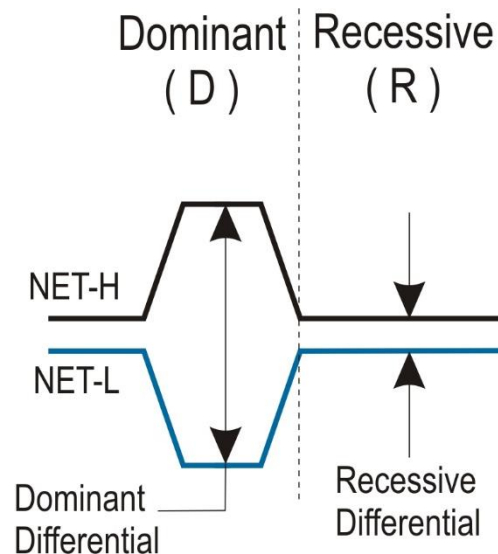

Because the transceiver subtracts the NET-H and NET-L signals to determine the bit values, any noise induced in the cable (the same noise is induced in both wires) is cancelled. Transceiver chips require NET-H and NET-L voltages to be within specific limits, otherwise a dominant (0) might be misinterpreted as a recessive (1) or vice-versa resulting in errors.

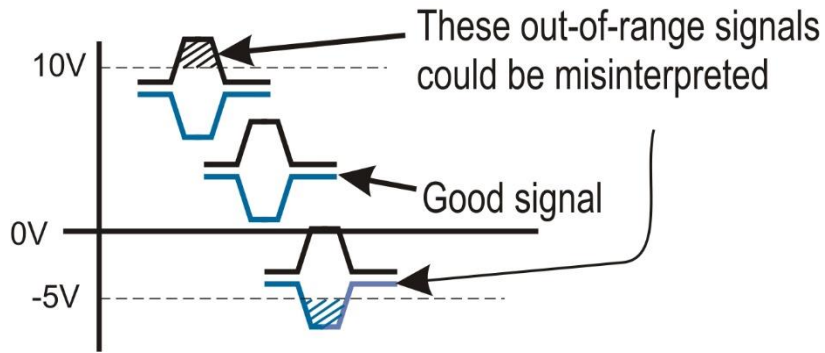

DC common mode voltage (caused by voltage drop in the cable) is the primary cause of the voltage shift illustrated above. Noise induced in the data wires also contributes to the voltage offset.

If the combination of DC common mode voltage and induced noise causes the signal voltages to exceed the transceivers' capabilities, bit errors are more likely to occur.

Six separate CAN voltage measurements are essential to rapid troubleshooting. The N2KMeter accurately measures these voltages as defined in the next diagram.

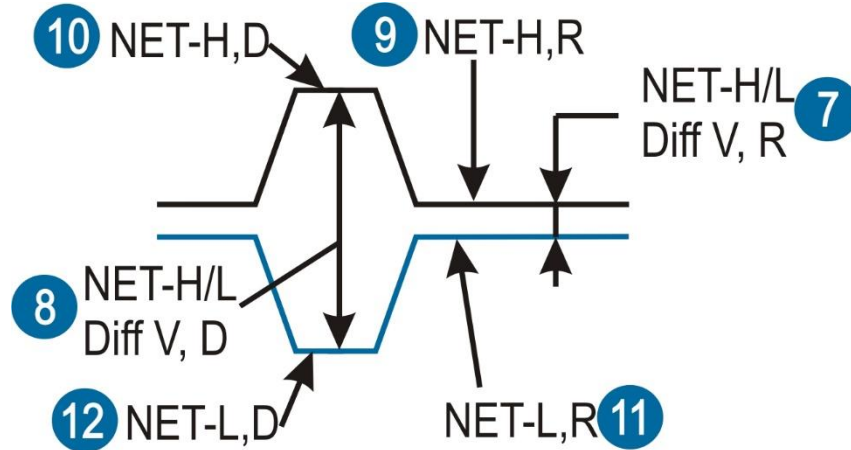

12 Common Mode Voltage (Switch Position 6)

The N2KMeter measures the worst-case total Common Mode Voltage (CMV) for your network (including DC CMV and noise).

Display



What it means

Worst-case total CMV recorded since the N2KMeter was plugged in or reset is 1.33V.



Common Mode Voltage cannot be determined because there is no bus activity.

12.1 What is Common Mode Voltage?

Common Mode Voltage is an incidental voltage that is common to both signal conductors in a differential transmission system. CMV manifests itself as a shift in signal voltage without any change in differential voltage.

Excessive CMV may cause signal voltages to exceed the capabilities of transceiver chips, ultimately resulting in communication errors.

The primary component of CMV is voltage drop in the power conductors. The cable resistance causes the NET-S voltage to drop from 12 VDC with increasing distance from the power supply. Similarly, the NET-C voltage increases proportionally from 0 VDC at the power supply. This offset results in each node having a slightly different reference point (NET-C), which causes an apparent shift in signal voltages from each node's point of view (the signal voltages don't really change, but the difference in NET-C makes it look that way).

Intermittent factors such as external interference, variations in network load current and electrical noise internal to nodes also contribute to CMV. Collectively, these intermittent factors are called "noise".

Total CMV is critical to network health. N2KMeter measures total CMV over time and records the maximum. To measure worst-case total CMV, leave the N2KMeter connected to the network for an appropriate period of time (one voyage, one watch, one day).

Thresholds

CMV High Fault	☹	5.5V
CMV High Warning	☺	2.5V

Notes About Common Mode Voltage (CMV)

- N2KMeter's CMV measurements are not affected by where on the network you take the measurement.
- DC CMV problems are typically caused when devices draw more current than expected or when cable resistance is higher than expected (too much cable) or a combination of both.
- CMV problems can be intermittent since few devices have a constant load current.

For ☹️ CMV levels we suggest:

- Check for devices that might be drawing more current than you expect
- Verify your network design with special attention to cable length and load current calculations
- Move the power supply toward the middle of the network, or toward the nodes that draw the most current
- Investigate adding another power supply to reduce voltage offset in NET-C
- High levels of external interference may require you to reduce the DC CMV limit below the 2.5V recommended in the NMEA 2000® Specification to keep total CMV below 5.5V

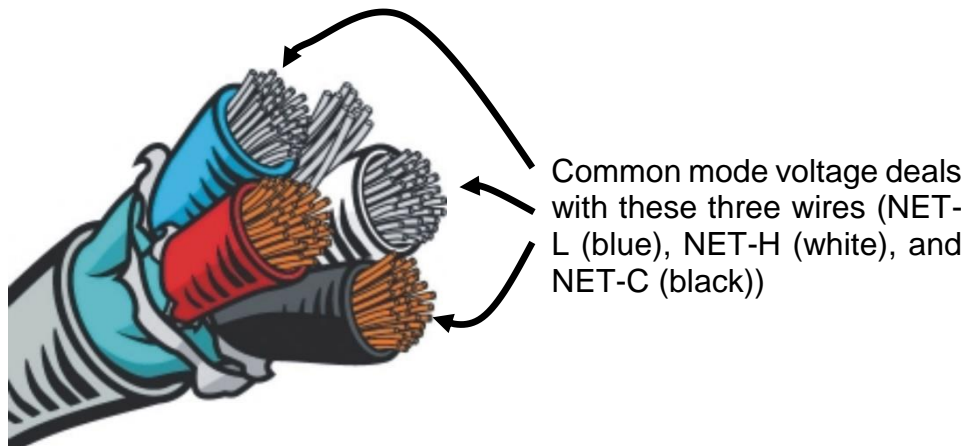

13 NET-H/L Differential V Recessive (Switch Position 7)

NET-H/L differential (Recessive) shows you the difference between NET-H and NET-L for recessive bits:

$$NET-H/L \text{ diff. } V(R) = NET-HV(R) - NET-LV(R)$$

7

9

11

Display

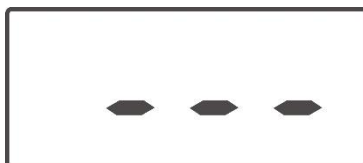

What it means

Current NET-H/L recessive voltage differential is 0.09V.



Minimum NET-H/L recessive voltage differential since the N2KMeter was plugged in or reset is 0.08V.



Maximum NET-H/L recessive voltage differential since N2KMeter was plugged in or reset is 0.09V.

Recessive differential bus voltage can not be measured because the bus is stuck dominant.

13.1 Importance of NET-H/L Differential V Recessive Measurement

Data bits (0's and 1's) are transmitted as differences in voltage between the NET-H and NET-L wires. The differential voltage measurements are essentially a measurement of "signal quality". The recessive differential voltage is ideally zero, but typically is plus or minus a few millivolts.

A recessive differential voltage that is not sufficiently close to zero may be misinterpreted by a transceiver as a dominant bit - resulting in communication errors.

Thresholds

Diff R Voltage High Fault	⊗	0.08V
Diff R Voltage Low Fault	⊗	-0.18V

13.2 What is “recessive?”

NMEA 2000® messages consist of 1’s and 0’s. The recessive state of the bus (where the differential voltage between NET-H and NET-L is close to zero) represents the logical value 1 (opposite from what you might expect). The bus is always in the recessive state except when a node is transmitting.

The N2KMeter measures the difference between NET-H and NET-L for recessive bits on the network, and if the difference is not close to 0 volts, N2KMeter indicates a fault.

For ☹️ NET-H/L differential recessive voltage levels we suggest:

- Check for shorts and opens on the NET-H and NET-L wires
- Check for a missing or bad terminator (should be two 120 ohm terminators from NET-H to NET-L - one at each end of the network)
- Disconnect nodes one at a time or temporarily split the network to check for faulty transceivers or cables.

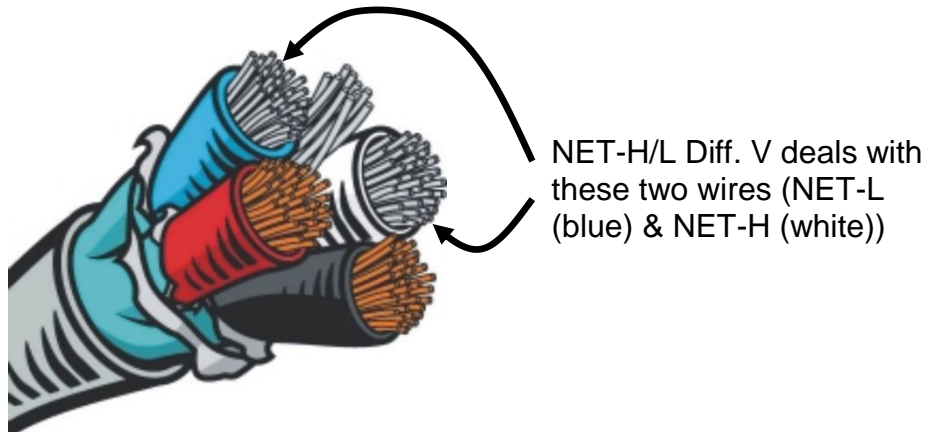

14 NET-H/L Differential V Dominant (Switch Position 8)

NET-H/L differential shows you the difference between NET-H and NET-L for dominant bits:

$$\text{NET-H/L diff. } V(D) = \text{NET-HV}(D) - \text{NET-LV}(D)$$

8

10

12

Display



Minimum NET-H/L dominant voltage differential since the N2KMeter was plugged in or reset is 1.00V.



Maximum NET-H/L dominant voltage differential since N2KMeter was plugged in or reset is 1.76V.

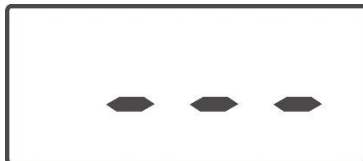

Dominant differential bus voltage can not be measured because there is no bus activity.

Thresholds

Diff D Voltage High Fault	⊘	3.00V
Diff D Voltage High Warning	☹	2.75V
Diff D Voltage Low Warning	☺	1.45V
Diff D Voltage Low Fault	⊘	1.20V

14.1 What is “Dominant”?

NMEA 2000® messages consist of 1's and 0's. The dominant state of the bus (where the differential voltage between NET-H and NET-L is around 2V) represents the logical value 0 (opposite from what you might expect). The bus can only be in the dominant state when a node is actively transmitting.

N2KMeter measures the difference between NET-H and NET-L for dominant bits on the network, and if the difference is not within acceptable limits, N2KMeter indicates a warning or a fault.

For ☹️ **NET-H/L differential dominant voltage levels we suggest:**

- Check for shorts and opens on the NET-H and NET-L wires
- Check for a missing, bad, or extra terminators (should be two 120 ohm terminators from NET-H to NET-L - one at each end of the network and no more!)
- Disconnect nodes one at a time or temporarily split the network to check for faulty transceivers or cables.

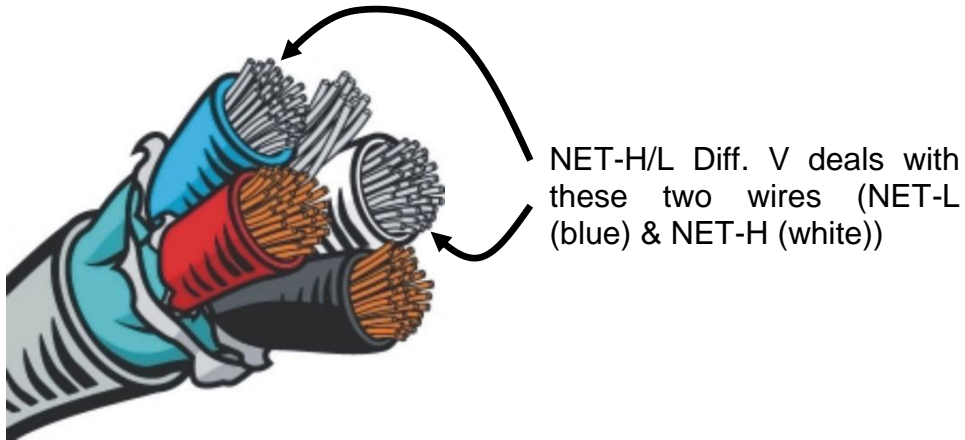

15 CAN Signal Thresholds (Switch Positions 9-12)

Thresholds:

Switch 9, 11

NET-H/L R Voltage High Fault	⊗	8.50V
NET-H/L R Voltage High Warning	☹	7.00V
NET-H/L R Voltage Low Warning	☹	-2.00V
NET-H/L R Voltage Low Fault	⊗	-3.00V

Switch 10

NET-H D Voltage High Fault	⊗	10.00V
NET-H D Voltage High Warning	☹	8.50V
NET-H D Voltage Low Warning	☹	-1.25V
NET-H D Voltage Low Fault	⊗	-2.25V

Switch 12

NET-L D Voltage High Fault	⊗	7.75V
NET-L D Voltage High Warning	☹	6.25V
NET-L D Voltage Low Warning	☹	-3.50V
NET-L D Voltage Low Fault	⊗	-4.50V

NMEA 2000® messages consist of 1's and 0's, which are represented as differences in voltage between the NET-H and NET-L wires. However, if the absolute voltage of the signal (measured to the V- wire at any node) is too high or too low, bits may not be received correctly. The N2KMeter measures each of the key NET-H, NET-L and Differential voltages, and if the readings are too high or low, the N2KMeter indicates a warning or fault.

Display

What it means

9 & 11

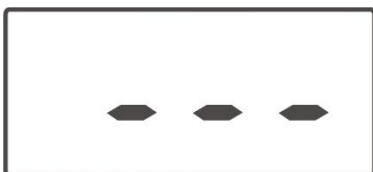

Recessive bus voltage cannot be measured because the bus is stuck dominant (or CAN wires are flipped).

10 & 12



Dominant bus voltage cannot be measured because there is no bus activity.

16 NMEA 2000® Glossary

Bandwidth: NMEA 2000®, like other serial networks, supports a certain number of bits per second sent on the wire. The actual network traffic is reported as a percentage of the theoretical maximum, and is called “% Bandwidth”. The N2KMeter's measurements include bandwidth lost due to bus errors and retries but most other diagnostic tools only include successful messages in bandwidth calculations.

CAN: NMEA 2000® is based on a low-level network standard known as CAN or CANbus. Other networks that use CAN include CANOpen, DeviceNet, and SDS. Although these networks are based on CAN, physical layer and upper layer protocol differences limit the use of the N2KMeter with these networks.

Frame Rate: NMEA 2000® messages are sent in one or more CAN message structures called Frames. Frame Rate is the number of these structures sent in 1 second. Since one NMEA 2000® message may require several CAN frames, the frame rate is not necessarily the same as the message rate.

Node Address: Each device on a NMEA 2000® network has a unique "Address", a number between 0 and 255. This Address is known as the Node Address. The number is displayed in hexadecimal notation on the N2KMeter display. Some network design specifications may refer to node addresses with decimal notation. Please refer to the conversion table in Section 20 on page 27 to convert between the two notations.

Noise: An undesirable intermittent voltage on a network signal or power wire.

P-P: Peak to peak measurements of varying voltage signals indicate the difference between the minimum and maximum values within a specific interval.

Ripple: A regular, repeated deviation from the mean voltage of a power or signal conductor.
Terminator: 1) A resistor connected at the end of a transmission line (network cable) to prevent signal reflections caused by impedance mismatches. NMEA 2000® requires two 120 ohm terminators, one at each end of the network. NMEA 2000® terminating resistors also define the recessive state of the network by ensuring that NET-H and NET-L return to zero differential after a dominant bit.

Transceiver: A transceiver is a circuit (typically a chip) that converts digital bits to/from the differential voltages on the network cable. *Transceiver* is a contraction of *transmitter* and *receiver*.

Transient: A temporary deviation from the mean voltage of a power or signal conductor.

17 Switch Settings

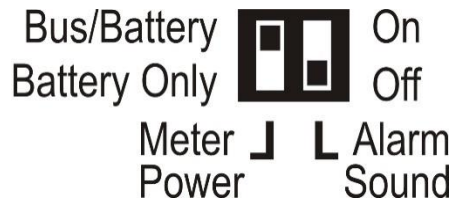

The N2KMeter has two configuration switches located in the battery compartment. The Meter Power switch (on left) selects between bus/battery power (powered by bus when available) and battery only power. Selecting battery-only power eliminates the possibility of inadvertently contributing to common mode voltage problems on extremely long networks, but limits the N2KMeter use to about 7 hours on fresh batteries.

The Alarm Sound switch (on right) enables and disables the “beep on error/transient” feature. With this feature enabled, the N2KMeter beeps each time a bus error or transient occurs when the selector switch is in the corresponding position.

18 Certifications



This device meets or exceeds the requirements of the following standard(s):

UL3111-1 Can/CSA C22.2

CAT II 30V

FCC

This device complies with Part 15 of the FCC Rules. Operation is subject to the following two conditions: (1) this device may not cause harmful interference and (2) this device must accept any interference received, including interference that may cause undesired operation.

NOTE: This equipment has been tested and found to comply with the limits for Class A digital device, pursuant to Part 15 of the FCC Rules. These limits are designed to provide reasonable protection against harmful interference when the equipment is operated in a commercial environment. This equipment generates, uses, and can radiate radio frequency energy and, if not installed and used in accordance with the instruction manual, may cause harmful interference to radio communications. Operation of this equipment in a residential area is likely to cause harmful interference, in which case the user will be required to correct the interference at his own expense.

Warning: Changes or modifications not expressly approved by Maretron could void the user's authority to operate the equipment.

Industry Canada

This Class (A) digital apparatus complies with Canadian ICES-003.



Marking of this equipment with the symbol CE indicates compliance with European Council Directive 89/336/EEC - The EMC Directive as amended by 92/31/EEC and 93/68/EEC.

Note: To maintain compliance with the limits and requirements of the EMC Directive, it is required to use quality interfacing cables and connectors when connecting this device. Refer to the cable specifications in the *Maretron NMEA 2000® Network Designer's Guide* for selection of cable types.

This device meets or exceeds the requirements of the following standard:

EN 61326:1997 including amendment A1:1998 - "Electrical equipment for measurement, control and laboratory use - EMC requirements."

Warning!

This is a Class A product. In a domestic environment this product may cause radio interference in which case the user may be required to take adequate measures.

Caution!

This equipment is neither designed for, nor intended for operation in installations where it is subject to hazardous voltages and/or hazardous currents.

19 Cables

The N2KMeter is designed for use with the supplied cable or the following Maretron replacement cable: CM-CG1-CF-01.0.

20 Hexadecimal to Decimal Conversion Table

Decimal	Hex
0	00
1	01
2	02
3	03
4	04
5	05
6	06
7	07
8	08
9	09
10	0A
11	0B
12	0C
13	0D
14	0E
15	0F
16	10
17	11
18	12
19	13
20	14
21	15
22	16
23	17
24	18
25	19
26	1A
27	1B
28	1C
29	1D
30	1E
31	1F
32	20
33	21
34	22
35	23
36	24
37	25
38	26
39	27
40	28
41	29
42	2A
43	2B
44	2C
45	2D
46	2E
47	2F
48	30
49	31
50	32
51	33
52	34
53	35
54	36
55	37
56	38
57	39
58	3A
59	3B
60	3C
61	3D
62	3E
63	3F

Decimal	Hex
64	40
65	41
66	42
67	43
68	44
69	45
70	46
71	47
72	48
73	49
74	4A
75	4B
76	4C
77	4D
78	4E
79	4F
80	50
81	51
82	52
83	53
84	54
85	55
86	56
87	57
88	58
89	59
90	5A
91	5B
92	5C
93	5D
94	5E
95	5F
96	60
97	61
98	62
99	63
100	64
101	65
102	66
103	67
104	68
105	69
106	6A
107	6B
108	6C
109	6D
110	6E
111	6F
112	70
113	71
114	72
115	73
116	74
117	75
118	76
119	77
120	78
121	79
122	7A
123	7B
124	7C
125	7D
126	7E
127	7F

Decimal	Hex
128	80
129	81
130	82
131	83
132	84
133	85
134	86
135	87
136	88
137	89
138	8A
139	8B
140	8C
141	8D
142	8E
143	8F
144	90
145	91
146	92
147	93
148	94
149	95
150	96
151	97
152	98
153	99
154	9A
155	9B
156	9C
157	9D
158	9E
159	9F
160	A0
161	A1
162	A2
163	A3
164	A4
165	A5
166	A6
167	A7
168	A8
169	A9
170	AA
171	AB
172	AC
173	AD
174	AE
175	AF
176	B0
177	B1
178	B2
179	B3
180	B4
181	B5
182	B6
183	B7
184	B8
185	B9
186	BA
187	BB
188	BC
189	BD
190	BE
191	BF

Decimal	Hex
192	C0
193	C1
194	C2
195	C3
196	C4
197	C5
198	C6
199	C7
200	C8
201	C9
202	CA
203	CB
204	CC
205	CD
206	CE
207	CF
208	D0
209	D1
210	D2
211	D3
212	D4
213	D5
214	D6
215	D7
216	D8
217	D9
218	DA
219	DB
220	DC
221	DD
222	DE
223	DF
224	E0
225	E1
226	E2
227	E3
228	E4
229	E5
230	E6
231	E7
232	E8
233	E9
234	EA
235	EB
236	EC
237	ED
238	EE
239	EF
240	F0
241	F1
242	F2
243	F3
244	F4
245	F5
246	F6
247	F7
248	F8
249	F9
250	FA
251	FB
252	FC
253	FD
254	FE
255	FF

21 Specifications

Environment

Storage Temperature	-40°C to 85°C
Operating Temperature	0°C to 40°C
Humidity	5% to 90% (non-condensing)

Maximum Limits

Voltage between any two terminals	±30 Vdc
-----------------------------------	---------

Power Supply

Network Power	90 mA @ 7 Vdc to 30Vdc
Battery Power	2 X AA Alkaline Batteries

Bus Power Voltage Measurement

Range	2V to 26V & reverse polarity
Calibrated Accuracy (DC)	0.5% ± 1 count
Calibrated Accuracy (P-P)	1.0% ± 2 counts

Shield Voltage Measurement

Range	-10V to 1V
Calibrated Accuracy	1.0% ± 2 counts

CAN Voltage Measurement

Range	-5.25V to 9.98V
Calibrated Accuracy (signal)	0.5% ± 20mV ± 2 counts
Calibrated Accuracy (differential)	1.0% ± 20mV ± 4 counts

22 Technical Support

If you require technical support for Maretron products, you can reach us in any of the following ways:

Telephone: 1-866-550-9100
Fax: 1-602-861-1777
E-mail: support@maretron.com
World Wide Web: <http://www.maretron.com>
Mail: Maretron, LLP
Attn: Technical Support
9014 N. 23rd Ave Suite 10
Phoenix, AZ 85021 USA

23 Maretron (90-Day) Limited Warranty

Maretron warrants the N2KMeter to be free from defects in materials and workmanship for **ninety (90) days** from the date of original purchase. If within the applicable period any such products shall be proved to Maretron's satisfaction to fail to meet the above limited warranty, such products shall be repaired or replaced at Maretron's option. Purchaser's exclusive remedy and Maretron's sole obligation hereunder, provided product is returned pursuant to the return requirements below, shall be limited to the repair or replacement, at Maretron's option, of any product not meeting the above limited warranty and which is returned to Maretron; or if Maretron is unable to deliver a replacement that is free from defects in materials or workmanship, Purchaser's payment for such product will be refunded. Maretron assumes no liability whatsoever for expenses of removing any defective product or part or for installing the repaired product or part or a replacement therefore or for any loss or damage to equipment in connection with which Maretron's products or parts shall be used. With respect to products not manufactured by Maretron, Maretron's warranty obligation shall in all respects conform to and be limited to the warranty actually extended to Maretron by its supplier. The foregoing warranties shall not apply with respect to products subjected to negligence, misuse, misapplication, accident, damages by circumstances beyond Maretron's control, to improper installation, operation, maintenance, or storage, or to other than normal use or service.

THE FOREGOING WARRANTIES ARE EXPRESSLY IN LIEU OF AND EXCLUDES ALL OTHER EXPRESS OR IMPLIED WARRANTIES, INCLUDING BUT NOT LIMITED TO THE IMPLIED WARRANTIES OF MERCHANTABILITY AND OF FITNESS FOR A PARTICULAR PURPOSE.

Statements made by any person, including representatives of Maretron, which are inconsistent or in conflict with the terms of this Limited Warranty, shall not be binding upon Maretron unless reduced to writing and approved by an officer of Maretron.

IN NO CASE WILL MARETRON BE LIABLE FOR INCIDENTAL OR CONSEQUENTIAL DAMAGES, DAMAGES FOR LOSS OF USE, LOSS OF ANTICIPATED PROFITS OR SAVINGS, OR ANY OTHER LOSS INCURRED BECAUSE OF INTERRUPTION OF SERVICE. IN NO EVENT SHALL MARETRON'S AGGREGATE LIABILITY EXCEED THE PURCHASE PRICE OF THE PRODUCT(S) INVOLVED. MARETRON SHALL NOT BE SUBJECT TO ANY OTHER OBLIGATIONS OR LIABILITIES, WHETHER ARISING OUT OF BREACH OF CONTRACT OR WARRANTY, TORT (INCLUDING NEGLIGENCE), OR OTHER THEORIES OF LAW WITH RESPECT TO PRODUCTS SOLD OR SERVICES RENDERED BY MARETRON, OR ANY UNDERTAKINGS, ACTS OR OMISSIONS RELATING THERETO.

Maretron does not warrant that the functions contained in any software programs or products will meet purchaser's requirements or that the operation of the software programs or products will be uninterrupted or error free. Purchaser assumes responsibility for the selection of the software programs or products to achieve the intended results, and for the installation, use and results obtained from said programs or products. No specifications, samples, descriptions, or illustrations provided Maretron to Purchaser, whether directly, in trade literature, brochures or other documentation shall be construed as warranties of any kind, and any failure to conform with such specifications, samples, descriptions, or illustrations shall not constitute any breach of Maretron's limited warranty.

Warranty Return Procedure:

To apply for warranty claims, contact Maretron or one of its dealers to describe the problem and determine the appropriate course of action. If a return is necessary, place the product in its original packaging together with proof of purchase and send to an Authorized Maretron Service Location. You are responsible for all shipping and insurance charges. Maretron will return the replaced or repaired product with all shipping and handling prepaid except for requests requiring expedited shipping (i.e. overnight shipments). Failure to follow this warranty return procedure could result in the product's warranty becoming null and void.

Maretron reserves the right to modify or replace, at its sole discretion, without prior notification, the warranty listed above. To obtain a copy of the then current warranty policy, please go to the following web page:

<http://www.maretron.com/company/warranty.php>