

# **SEAVIEW**

**ELEVATE YOUR ELECTRONICS**

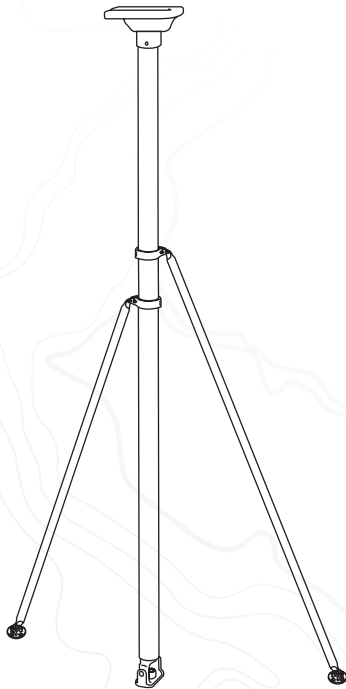

## **INSTALLATION INSTRUCTIONS**

For Seaview Pole Kit:

**RM848S**

Refer to website for most up to  
date instructions and videos.

**[WWW.SEAVIEWGLOBAL.COM](http://WWW.SEAVIEWGLOBAL.COM)**

# PARTS INCLUDED

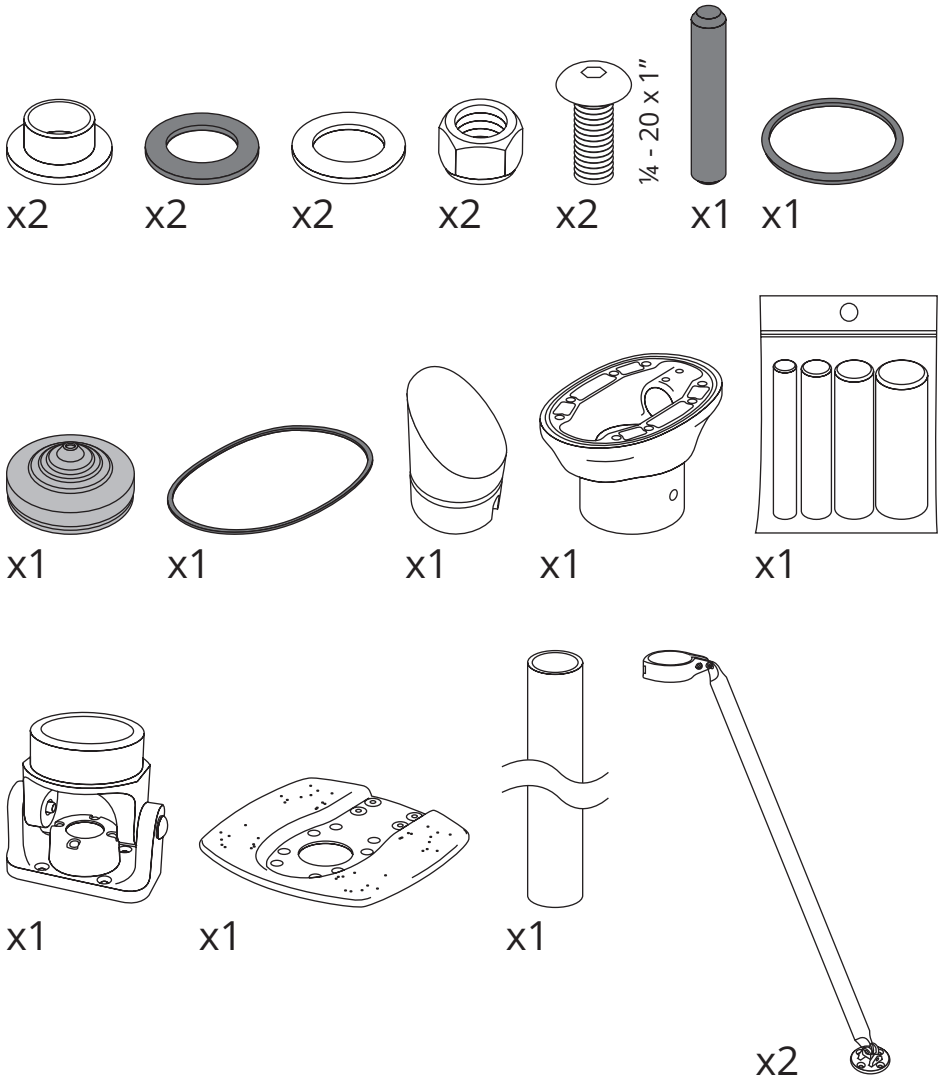

# TOOLS NEEDED

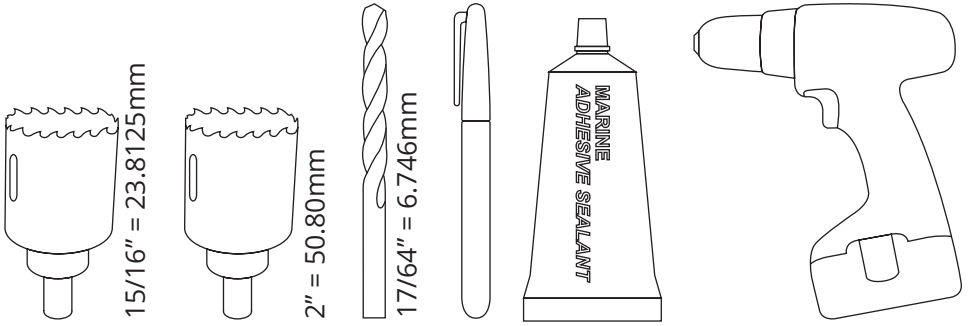
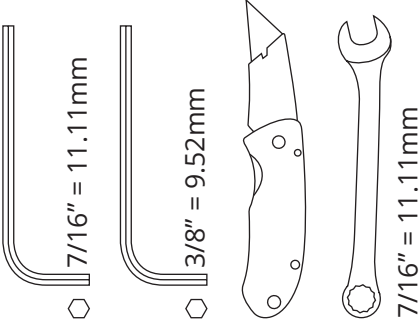

Before beginning please make sure that the Seaview Top Plate will face forward.

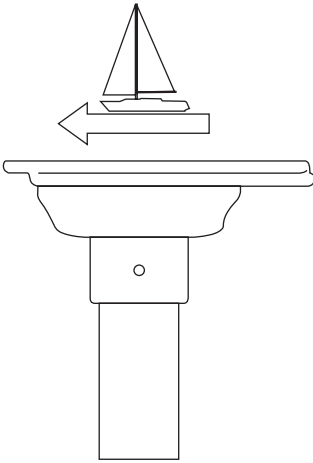

- 1** Place the provided drill template on top of your Seaview Top Plate. Using the Make and Model Guide in the Seaview Top Plate instructions mark the appropriate holes to drill.

Note: That the Seaview Top Plate and template may look different than pictured depending on which electronic device you are mounting.

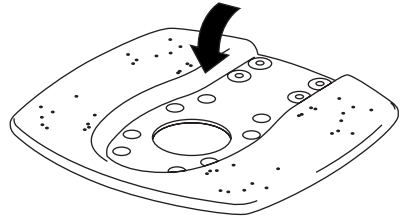
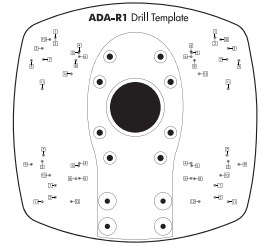

- 2** Using a 17/64" (6.746mm) drill bit, drill the four holes that you marked.

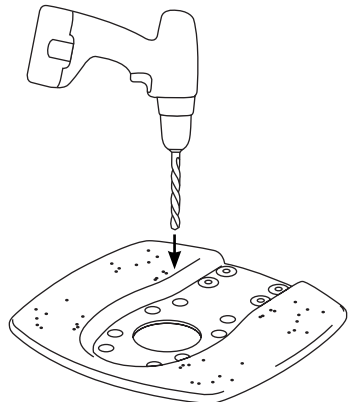

# 3

Insert the black light bar pin into the modular top of the pole kit.

If you are not using a light bar then insert the plastic plug into the back of the modular top. Make sure that the plug snaps in place from the light bar pin.

If you are using a light bar, do not use the black light bar pin.

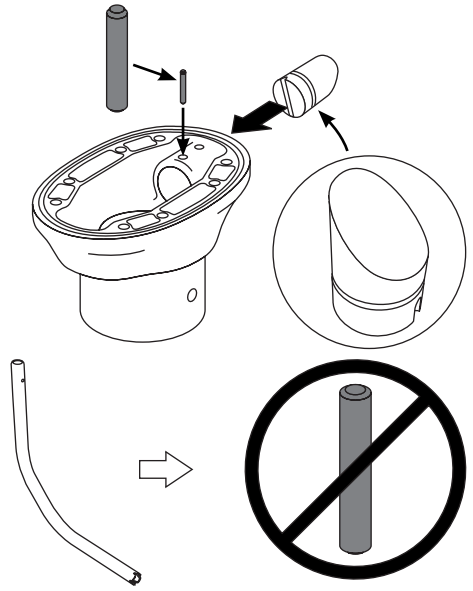

# 4

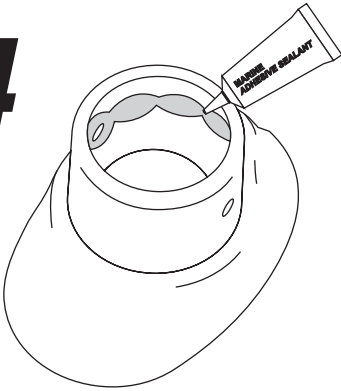

Apply marine adhesive sealant to the inside of the modular top where the pole will slide into. Be sure to get around the bolt holes.

# 5

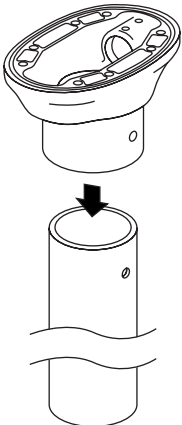

Slide the modular top assembly onto the top of the pole making sure that the bolt holes line up.

**6** Secure the modular top by threading the two 1/4-20 x 1" bolts into the plastic shoulder washers into the nut.

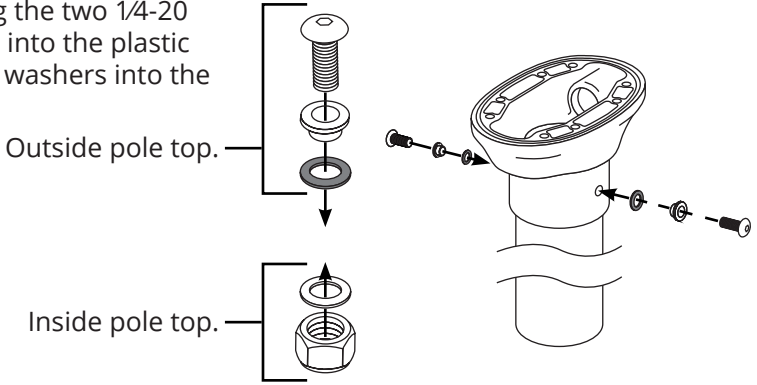

**7** Place the rubber gasket into the groove on the top of the modular top and then place the Seaview Top Plate on top.

Make sure that the eight bolt holes line up with the eight bolt holes on the modular top.

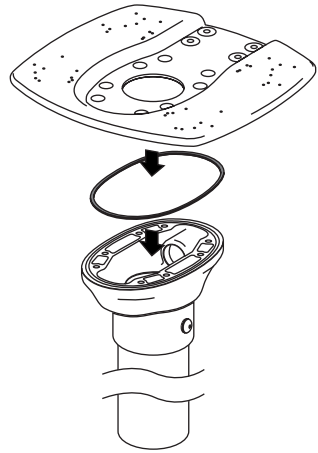

**8** Insert the rubber cable grommet into the top of the Seaview Top Plate.

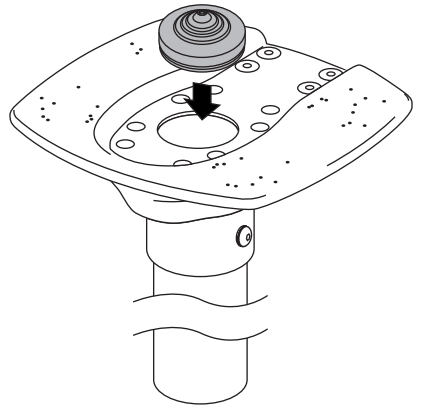

**9** Secure the Seaview Top Plate to the modular top using the eight bolts included in your Seaview Top Plate kit.

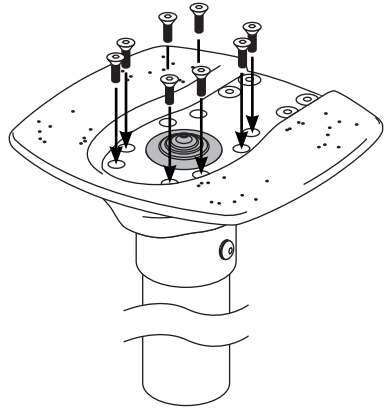

**10** Apply marine adhesive sealant around the base of the modular top.

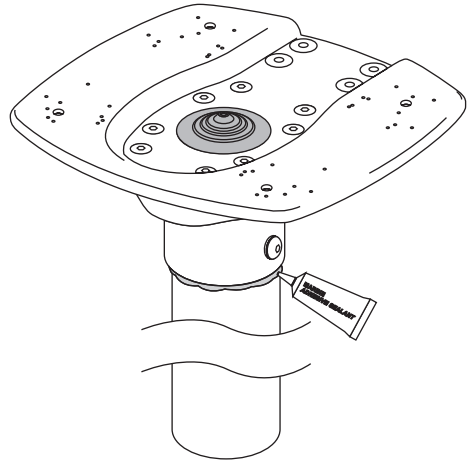

**11** Remove the two bolts from the adjustable pole base.

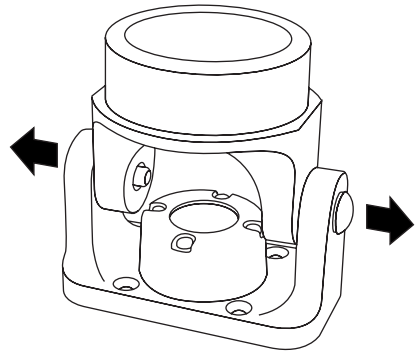

**12** Separate the two halves of the adjustable base.

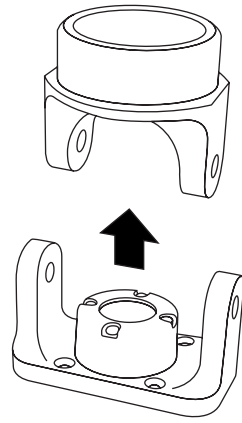

**13** Place the lower portion of the adjustable base onto the mounting surface.

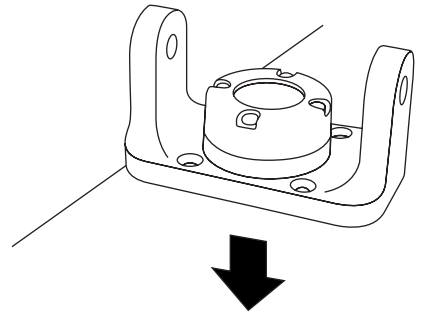

**14** Mark the four base holes for drilling.  
Be sure to also mark a hole for drilling for the cabling.

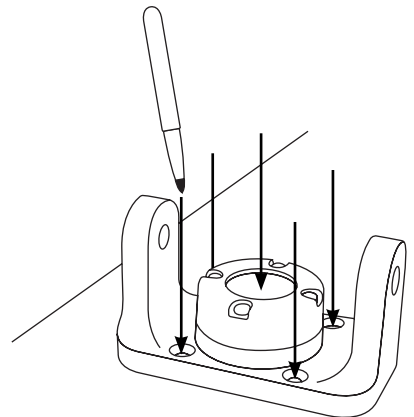



**15** Remove the lower portion of the adjustable base from the mounting surface.

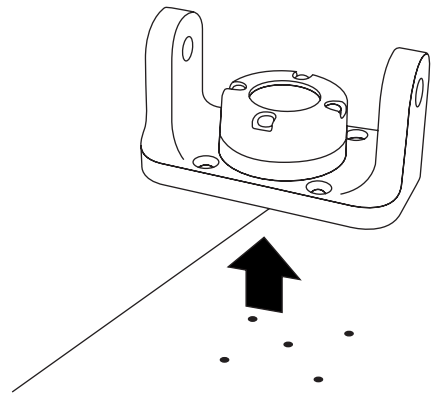

**16** Drill out the four holes for mounting the adjustable base.

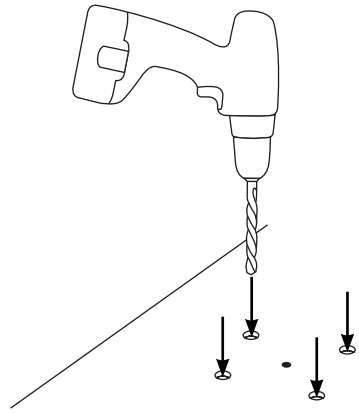

**17** Using a hole saw, cut a hole for the cabling.

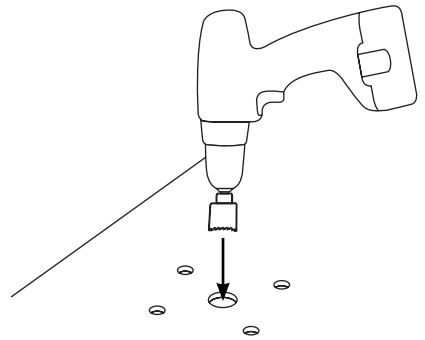

# 18

Remove the four screws holding the Cable Gland together and remove the outer housing. (Refer to Cable Gland Installation Instructions)

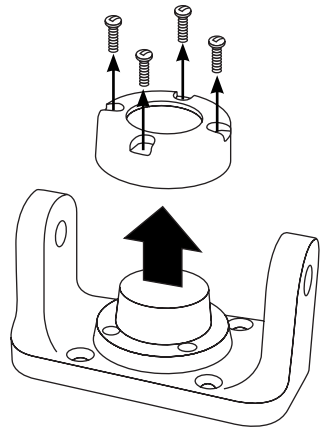

# 19

Remove the rubber grommet.

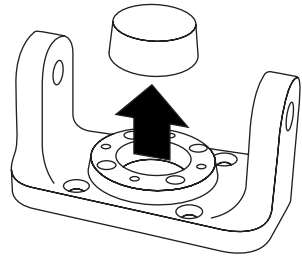

# 20

Drill a hole in the rubber grommet.

**Tip:** Use the provided drill tube instead of a drill bit for a cleaner cut.

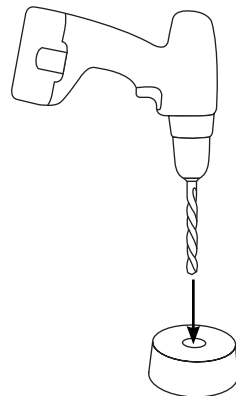

**21** Using a sharp knife slice the rubber grommet from the center drill hole outward.

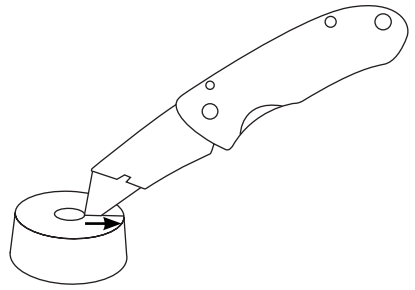

**22** Route the cable through the mounting surface, lower adjustable base and rubber grommet.

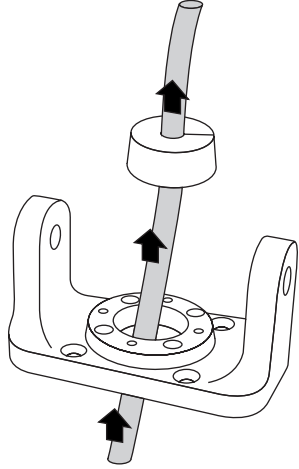

**23** Secure the outer shell of the Cable Gland using the four screws.

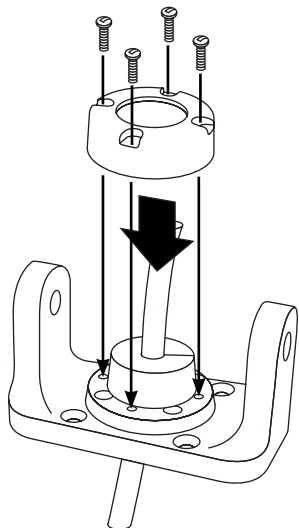

**24** Apply marine adhesive sealant to the top half of the adjustable base.

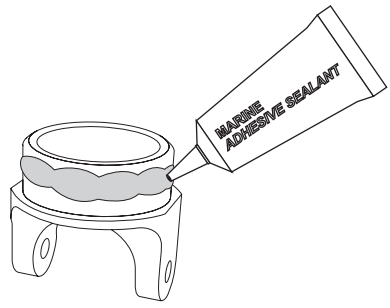

**25** Slide the pole onto the top half of the adjustable base.

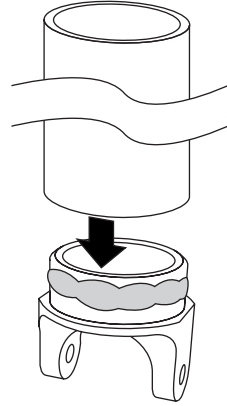

**26** Insert four nylon washers into the bottom half of the adjustable base as shown.

Slide the top half of the adjustable base into the bottom half, make sure that the bolt holes lineup.

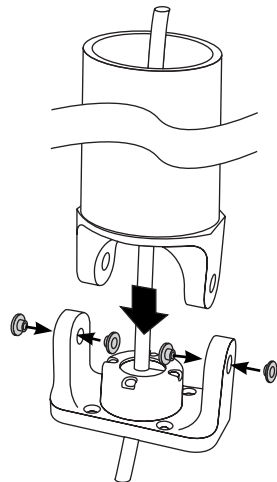

**27** Insert the locking washer, stainless steel washer and the two bolts that were removed in step #11.

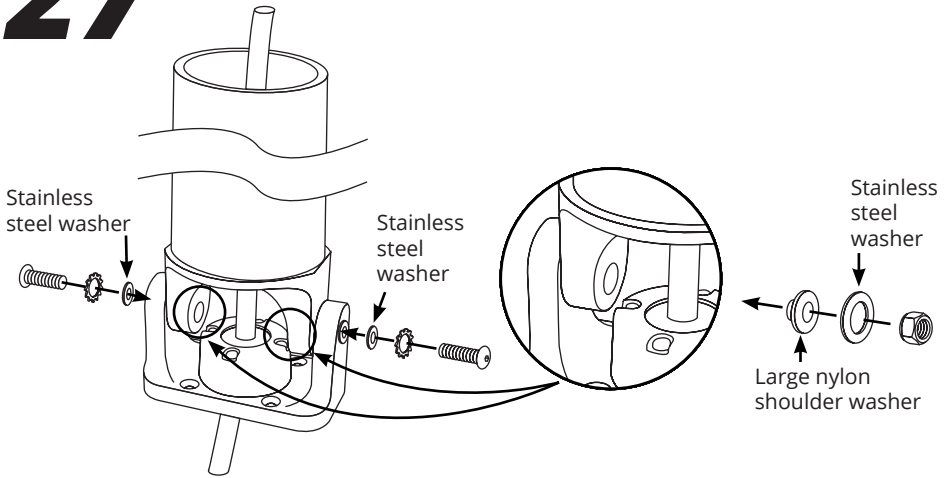

**28** Apply marine adhesive sealant to the bottom of the adjustable base.

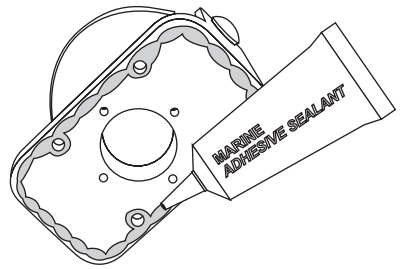

**29** Secure the adjustable base and pole assembly to the mounting surface with your provided hardware.

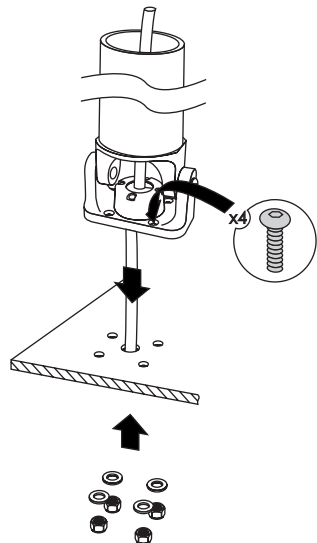

# 30

Insert the 48" strut into a clamp. Using an allen wrench tighten the clamp around the pole. Repeat this for the other 48" strut.

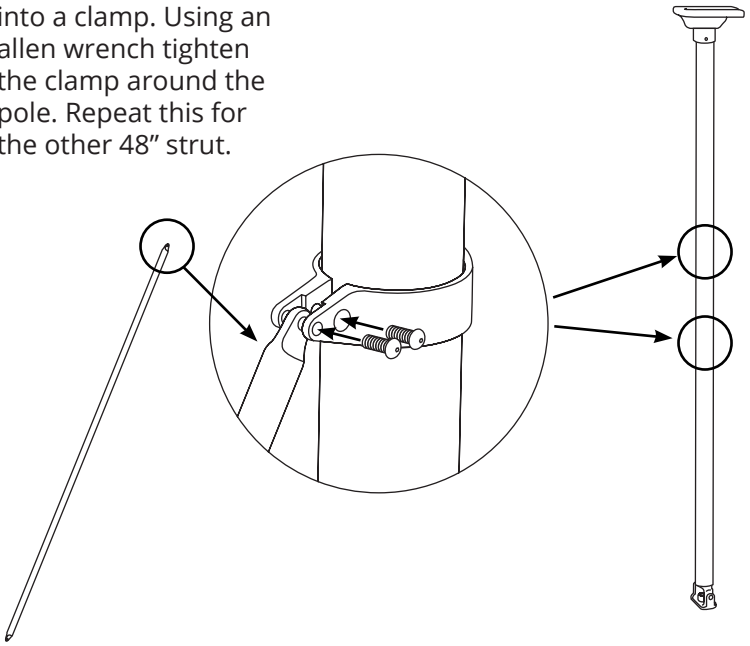

---

# 31

Using an allen wrench bolt the strut pad-eye onto a 48" strut.

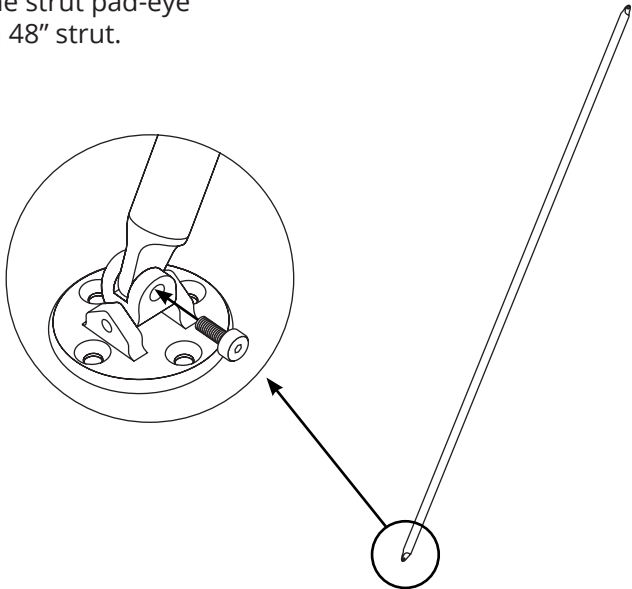

# 32

Completed assembly.

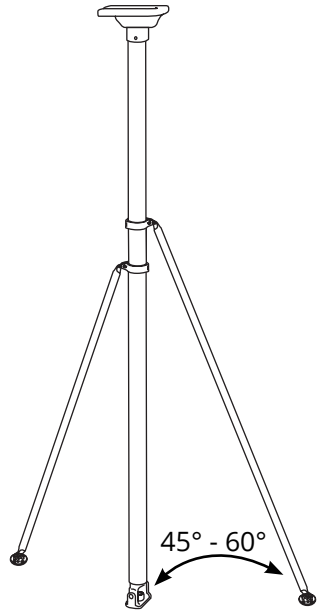

The background of the entire page is a light gray topographic map with white contour lines. The lines are irregular and wavy, representing terrain elevation. The map covers the entire page, with the text elements overlaid on it.

***SEAVIEW***///  
***ELEVATE YOUR ELECTRONICS***

***SEAVIEW***///

Tel: 800-655-7922  
[www.seaviewglobal.com](http://www.seaviewglobal.com)

***EUROPEAN OFFICE***

Tel: +33 4 94 53 27 70  
[www.seaviewprogress.com](http://www.seaviewprogress.com)

3-062618